

Regulation of Gene Expression

Case report

- A 10 year old boy presented with signs and symptoms and subsequent laboratory investigation reports suggestive of Acute lymphoblastic leukaemia. Patient was receiving Methotrexate as a part of this treatment. After several weeks of chemotherapy with methotrexate, the boy showed signs of resistance to treatment. What could be the most likely mechanisms to explain this resistance to methotrexate?

Objective

- What is Gene expression
- Necessity of regulation of gene expression
- Different types of gene regulation
- Gene regulation in prokaryotes
 - Lac operon
 - Tryptophan operon
- Gene regulation in Eukaryotes
 - At transcription level
 - At translation
 - Modification of DNA
- DNA regulatory proteins

- What is gene expression?
 - Formation of gene products
 - RNA and **Protein**
- Necessity of Gene Expression and regulation
 - Normal growth , development and functioning of an organism
 - Production of gene product according to the requirement of the body

Type of gene expression

- Constitutive
 - Occur all the time and at a relatively constant rate
- Regulated
 - Transcribed only when needed

Regulation of gene expression

- Positive regulation---- Enhancer/Activator
- Negative regulation----Repressor/ Silencer

Temporal responses to regulatory signal

Type A

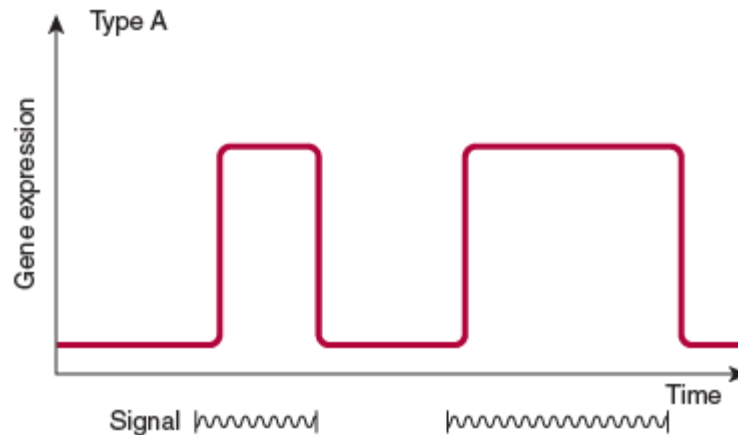

observed in prokaryotes in response to sudden changes of the intracellular concentration of a nutrient
in higher organisms after exposure to inducers such as hormones, nutrients, or growth factors

Type B

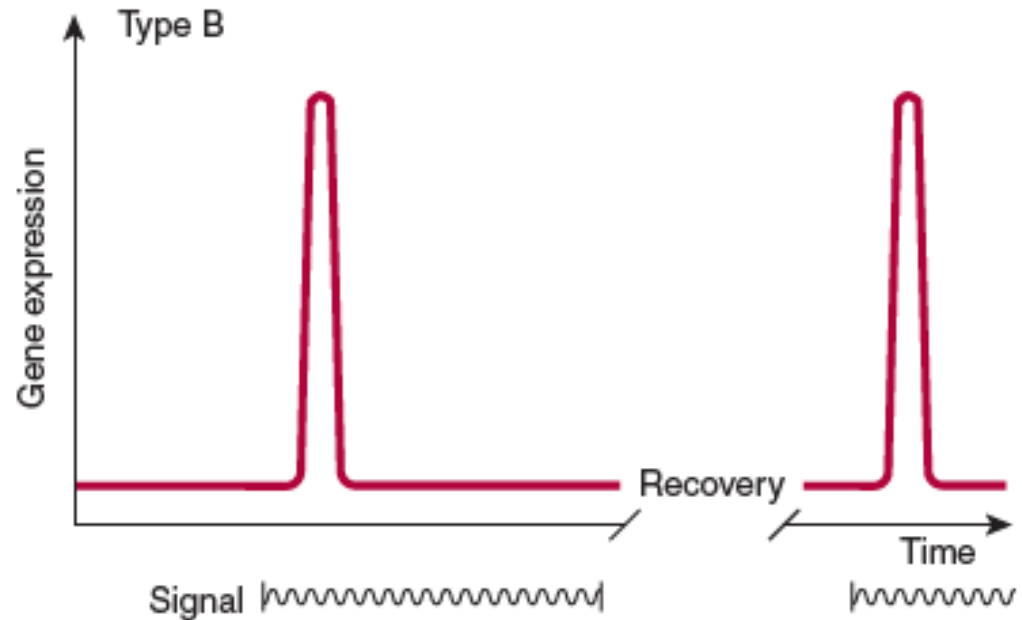

occurs during development of an organism, when only the transient appearance of a specific gene product is required

Type C

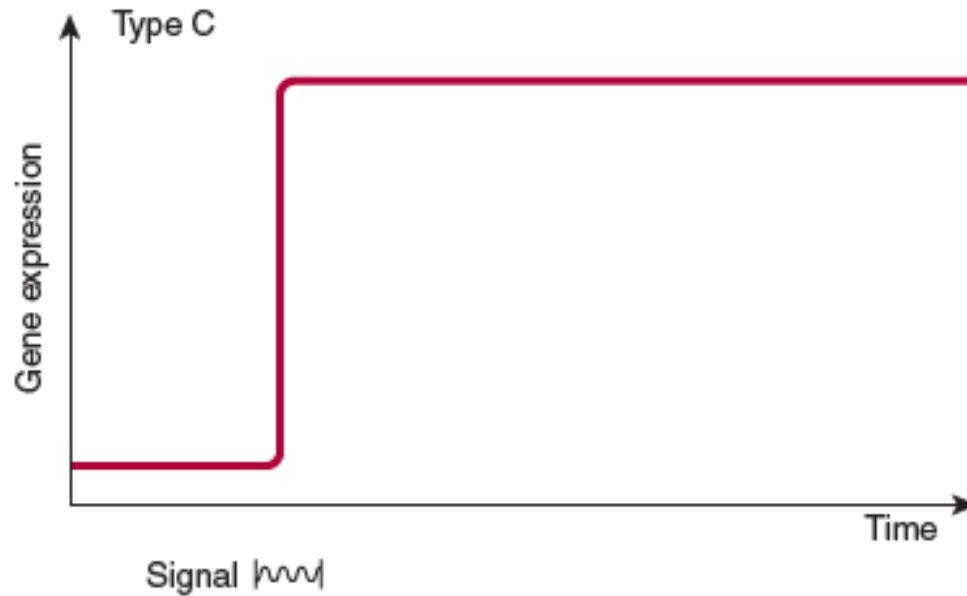

Occurs during the development of differentiated function in a tissue or organ

Stages of regulation of gene expression

- 1. **Transcription**
- 2. Post transcriptional modification
- 3. Translation
- 4. Post translational modification
- 5. RNA degradation
- 6. Protein degradation

Few specialized genetic and regulatory terms

Operon

groups of genes sequentially arranged on the chromosome along with the regulatory elements that determine their transcription

Polycistronic mRNA

Constitutive /House keeping gene

Expressed at a constant level

Inducible gene/Regulated gene

expressed only under certain condition

Gratuitous inducer: Acts as inducer but not as substrate

An example is isopropylthiogalactoside (IPTG)

Cis acting elements and Trans acting molecules

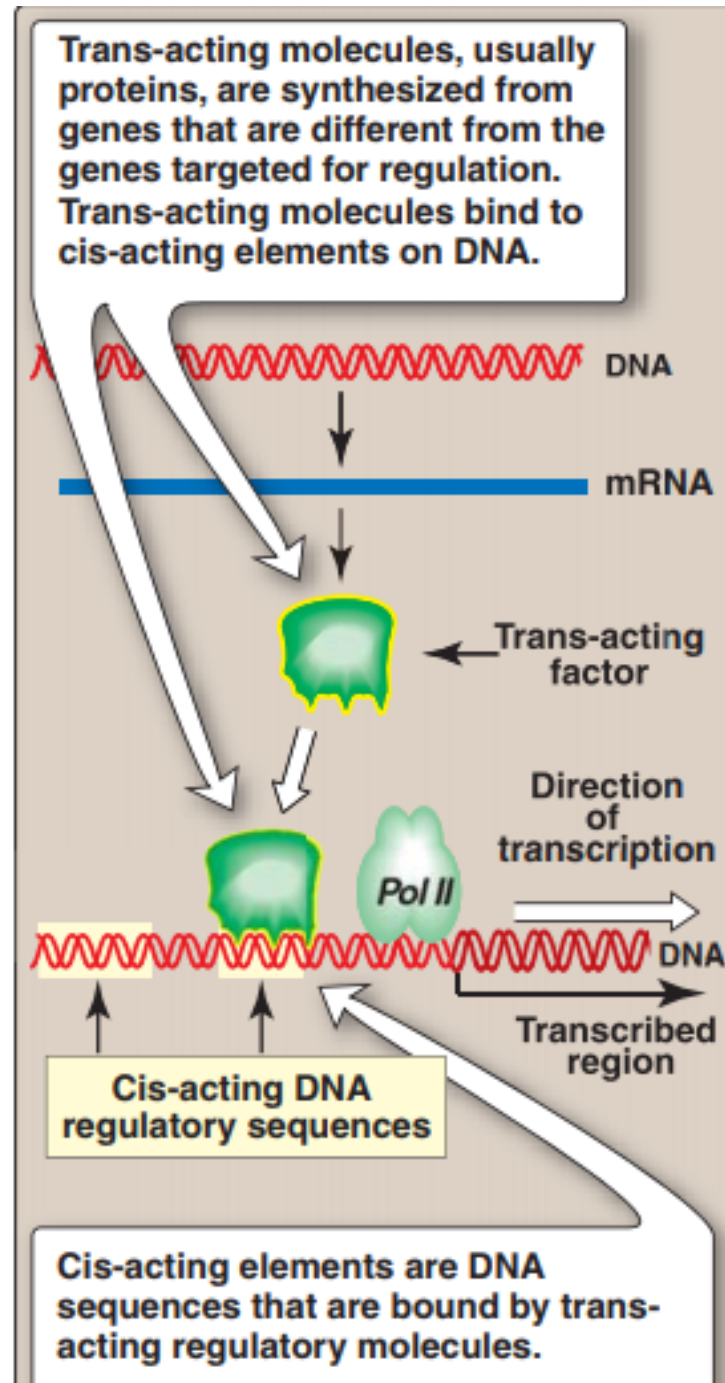

Regulation of Prokaryotic Gene Expression

- Transcription is the primary site of regulation.

Role of Promoters

Prokaryotic promoters share two regions of highly conserved nucleotide sequence

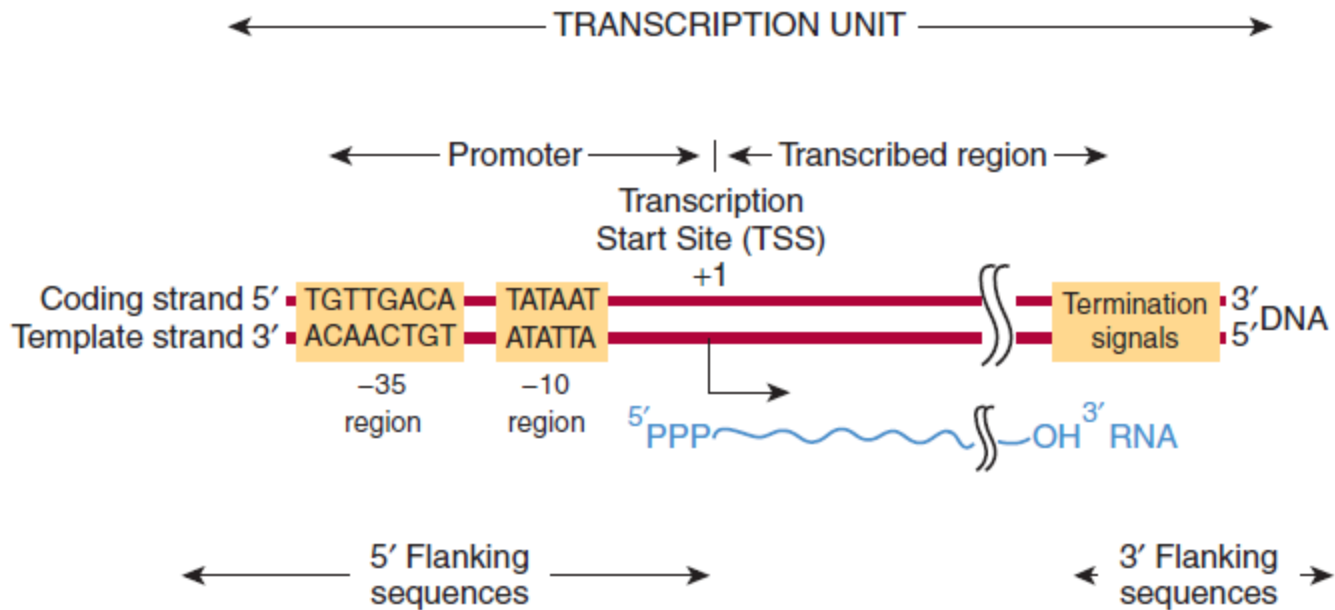

Promoter: A regulatory region of DNA that serves to bind RNA polymerase II that in turn binds other substances that will lead to initiation of transcription

Operon Model

Described by Jacob and Monod in 1961

Hypothesis: Based on the regulation of lactose metabolism by the intestinal bacterium *E. coli*

Led to the discovery of basic principles of Gene transcription activation and Repression

Type of Operon

- Catabolic Operon
 - Regulates the gene expression whose product have a catabolic role
 - e,g. Lac operon

- Anabolic Operon
 - Genes of anabolic pathway such as synthesis of amino acids are coordinately regulated
 - e,g. Tryptophan operon

Lac Operon

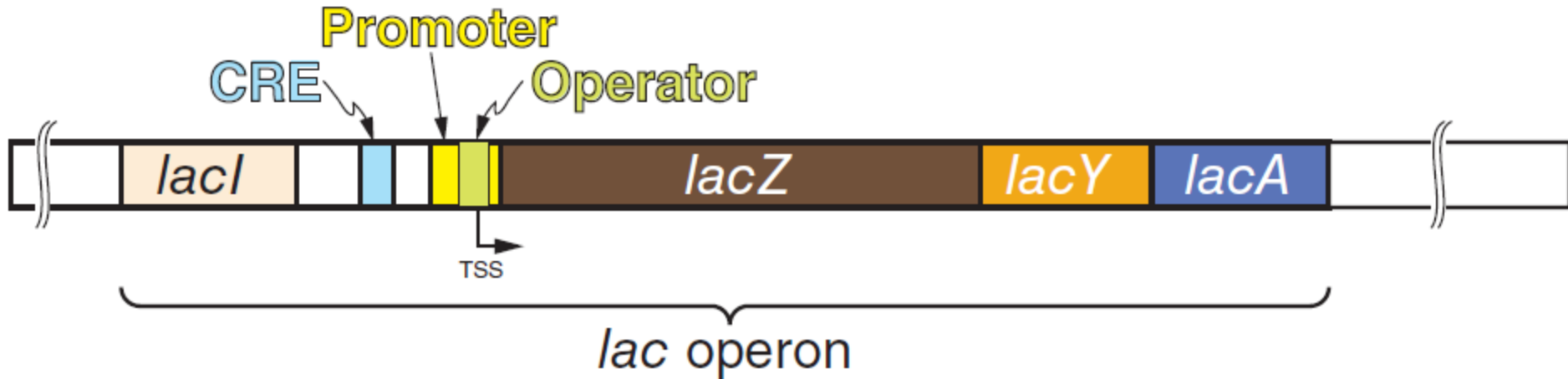

lacI gene encoding repressor

CRE: cAMP response element

Regulatory region : Promoter : RNAP binds

Operator: Repressor binds

Structural genes:

lac Z: β Galactosidase

lac Y: Permease

lac A:Thiogalactoside transacetylase

- The **operator locus** is a region of double-stranded DNA that exhibits a twofold rotational symmetry and an inverted palindrome (indicated by arrows about the dotted axis) in a region that is 21 bp long, as shown below:

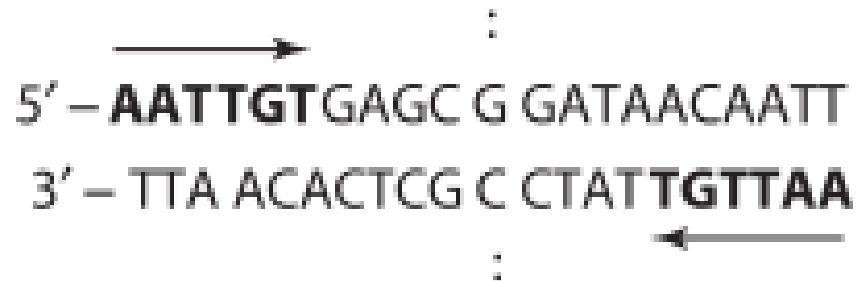

The binding occurs mostly in the **major groove**

The **operator locus** is between the **promoter site** and the transcription initiation site of the **lacZ gene**

A

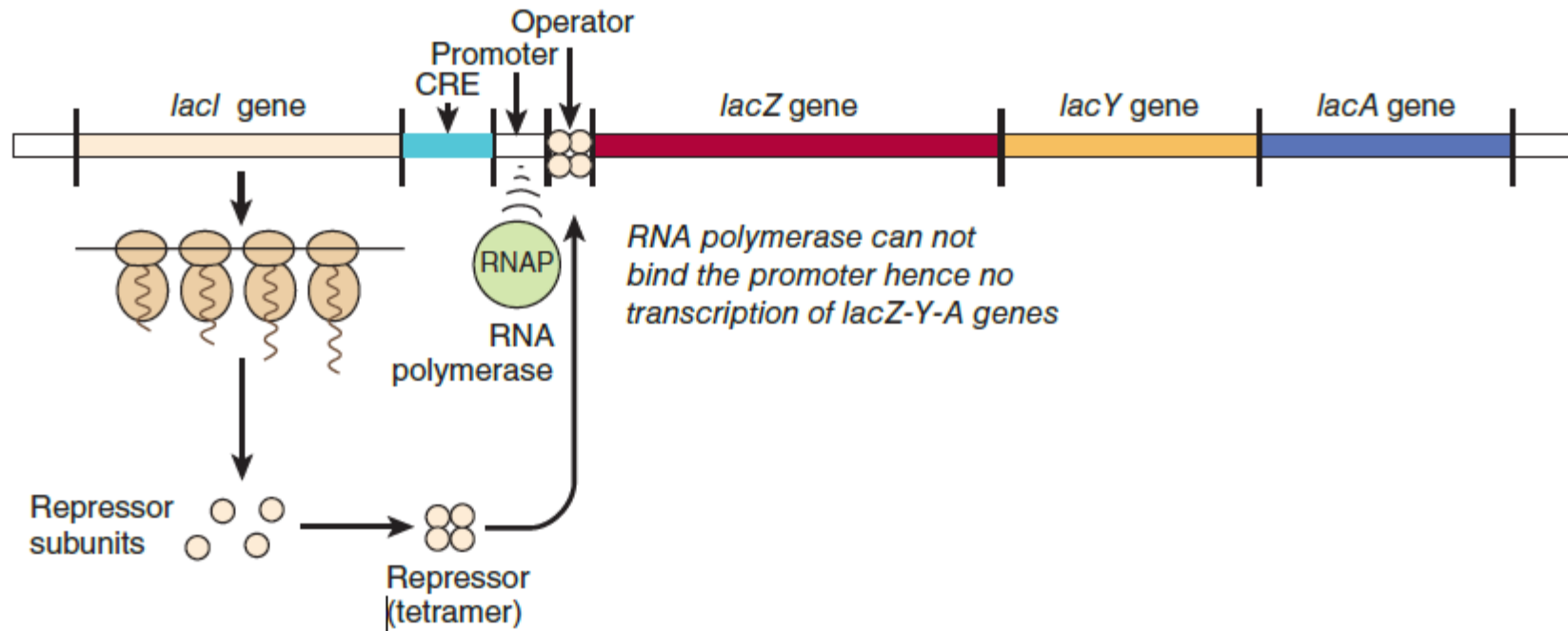

B

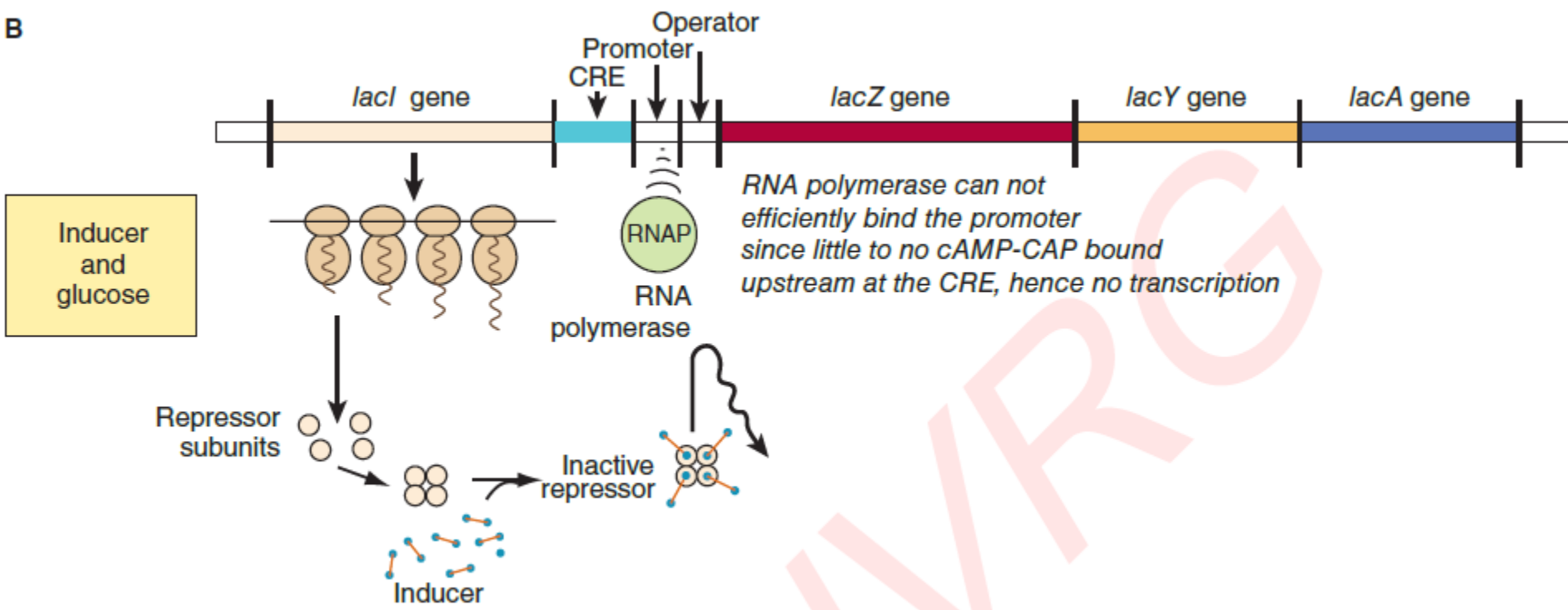

C

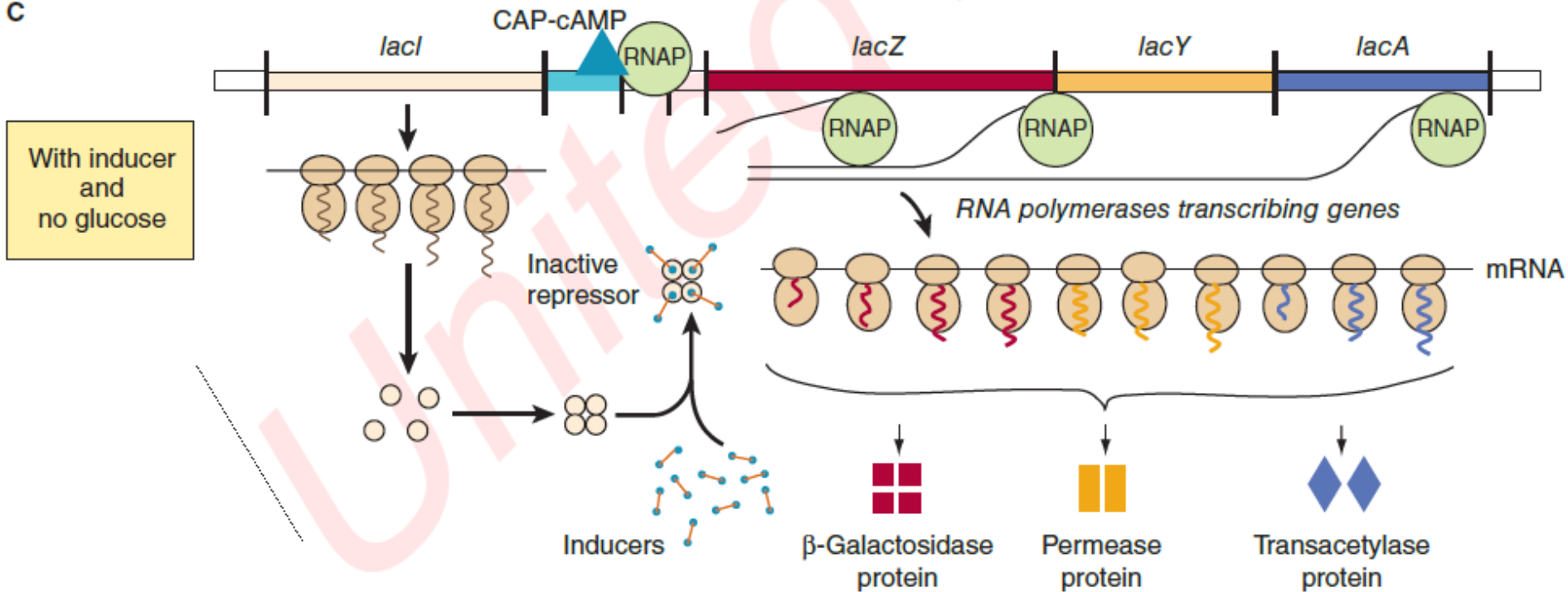

Lactose acts both as inducer and substrate

Tryptophan Operon

- Trp operon contains 5 structural genes
- Trp operon is subject to negative control
- Trp facilitates the binding of the repressor to the operator
- Trp is a corepressor
- Trp operon also regulated by attenuation
 - Transcription initiated but terminated well before completion

Transcriptional attenuation occur in Prokaryotes but not in Eukaryotes

Attenuation of transcription of the trp operon when tryptophan is plentiful.

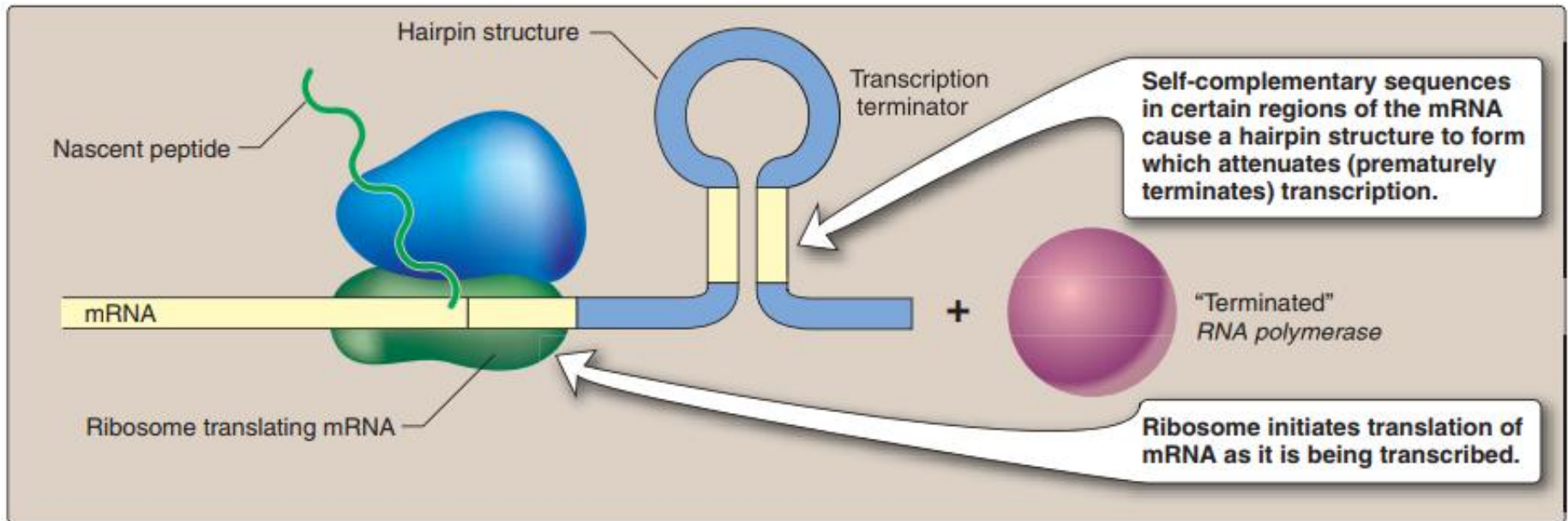

Coordination of transcription and translation in prokaryotes

- **1. Stringent response**
-
- **2. Regulatory ribosomal proteins**

Regulation of transcription by the stringent response to amino acid starvation

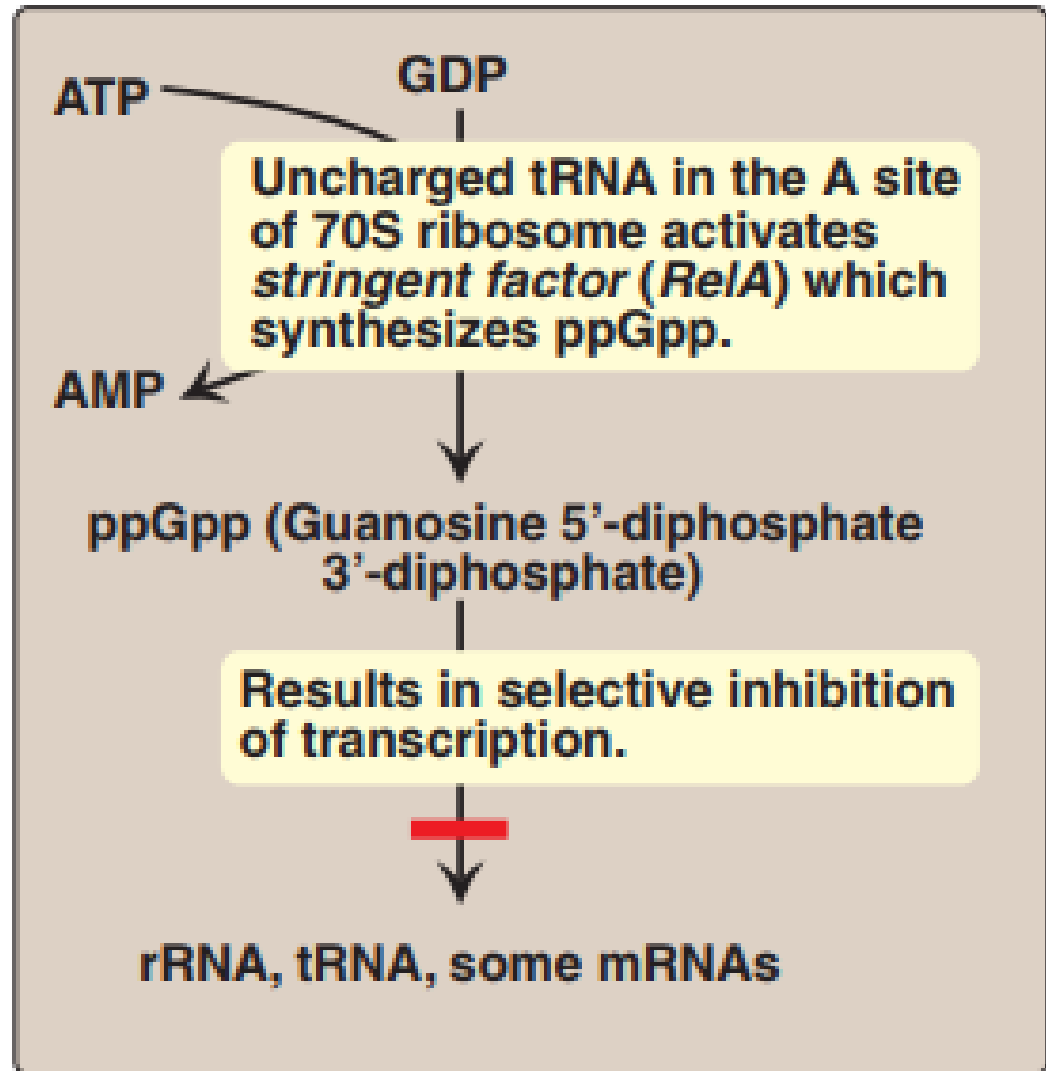

Regulation of translation by an excess of ribosomal proteins.

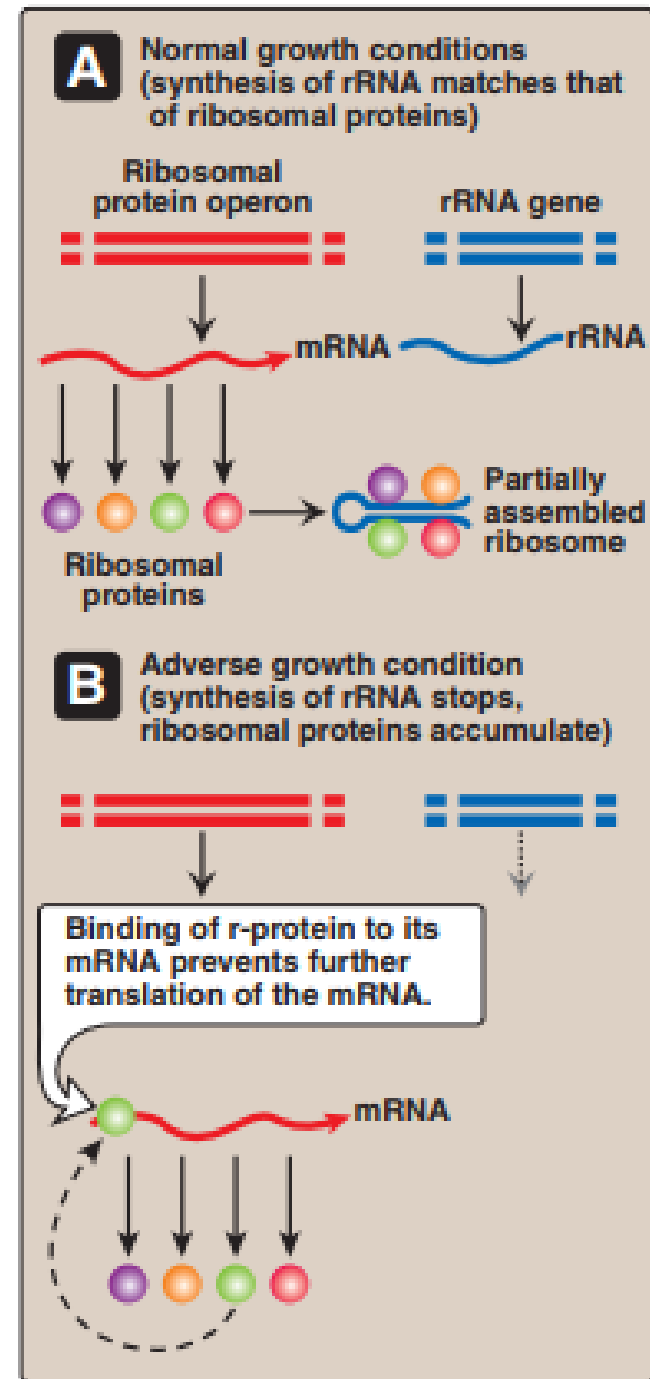

MCQ

- Which of the following mutations is most likely to result in reduced expression of the lac operon?
- A. i^- (no repressor protein made)
- B. O_c (operator cannot bind repressor protein)
- C. Cya^- (no adenylyl cyclase made)
- D. Functionally impaired glucose transporter

Regulation of Eukaryotic Gene Expression

- Transcription is the primary site of regulation
- Role of Promoter

Schematic showing the **transcription control regions** in a hypothetical mRNA-producing eukaryotic gene transcribed by RNA polymerase II

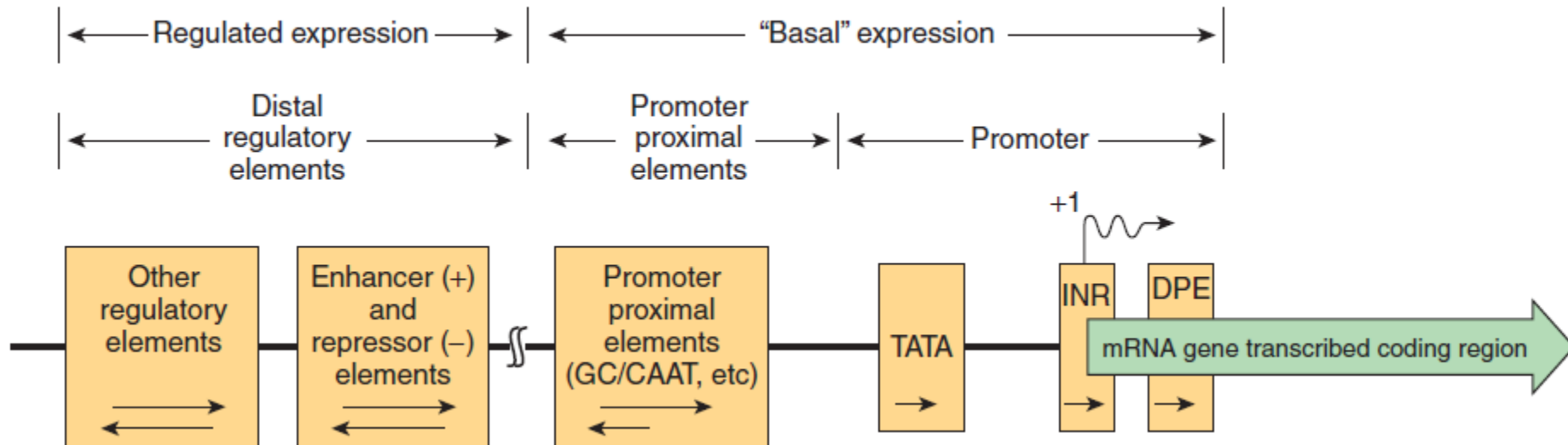

The eukaryotic basal transcription complex

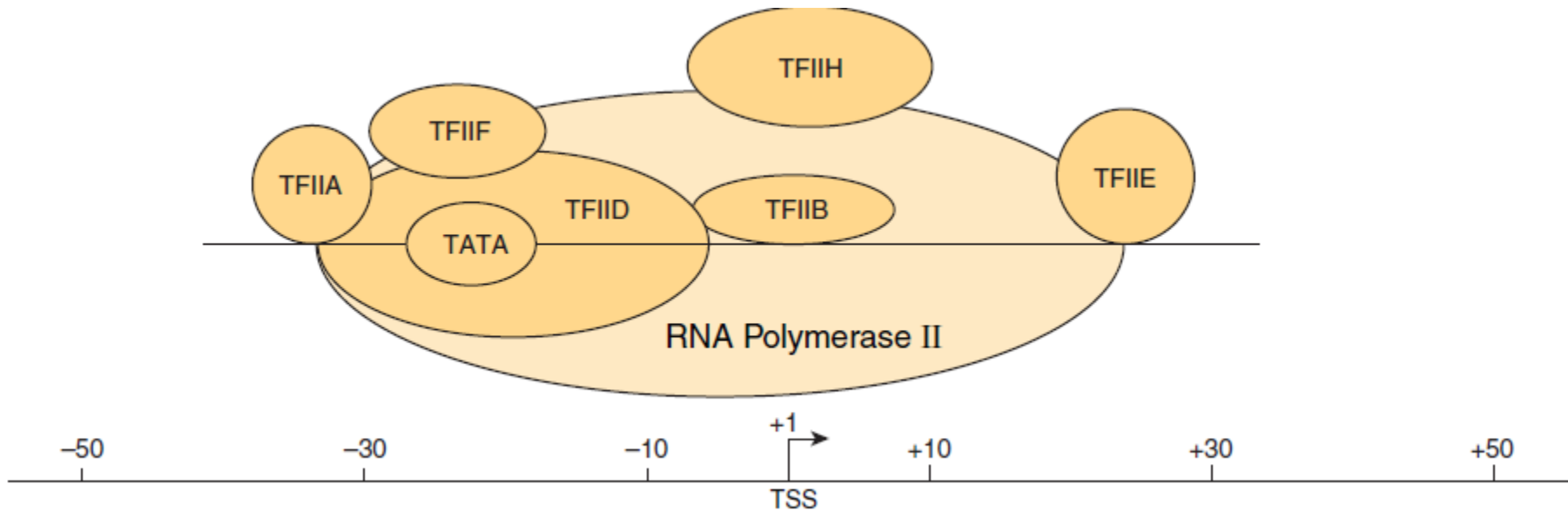

Stages of Regulation of Eukaryotic Gene Expression

- A. Coordinate regulation
 - 1. Galactose circuit
 - Coordinated expression mediated by Gal4
 - 2. Hormone response system
 - Intracellular receptors
 - Cell surface receptors

Regulation of Galactose circuit in yeast

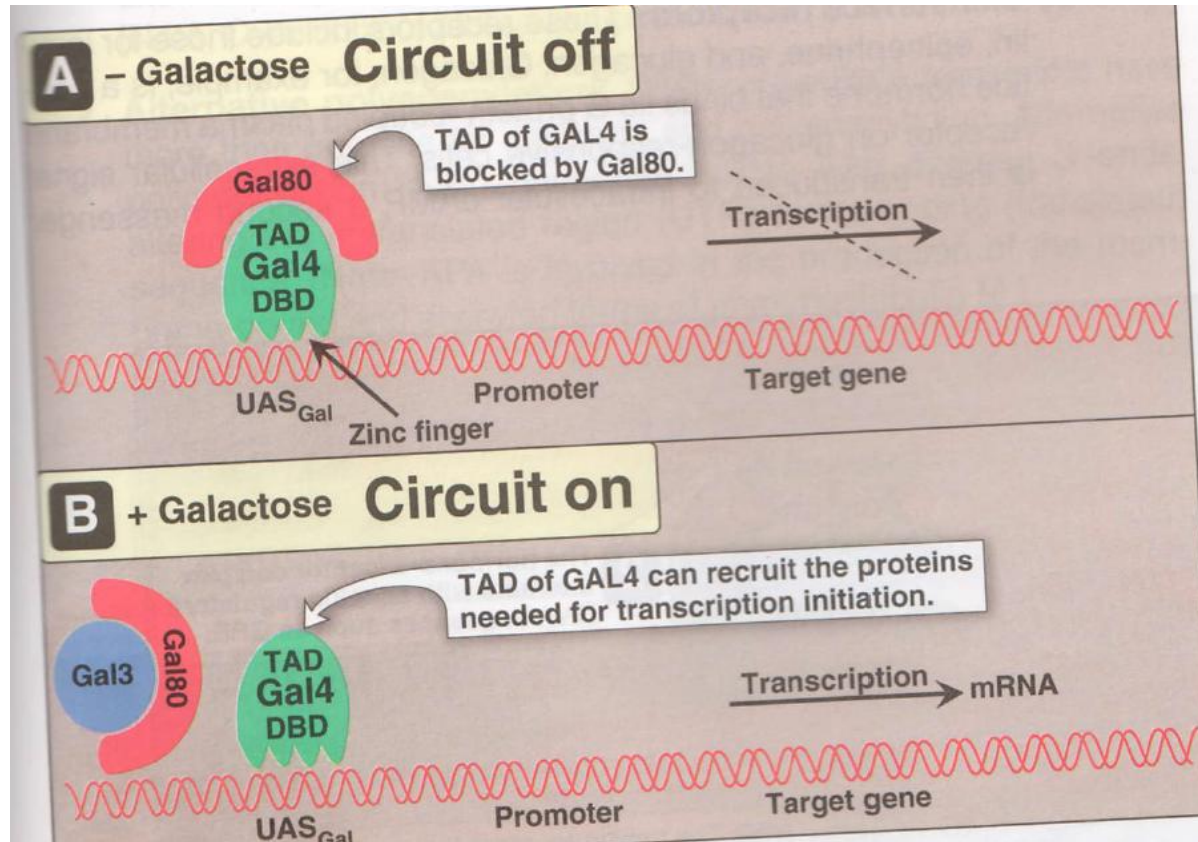

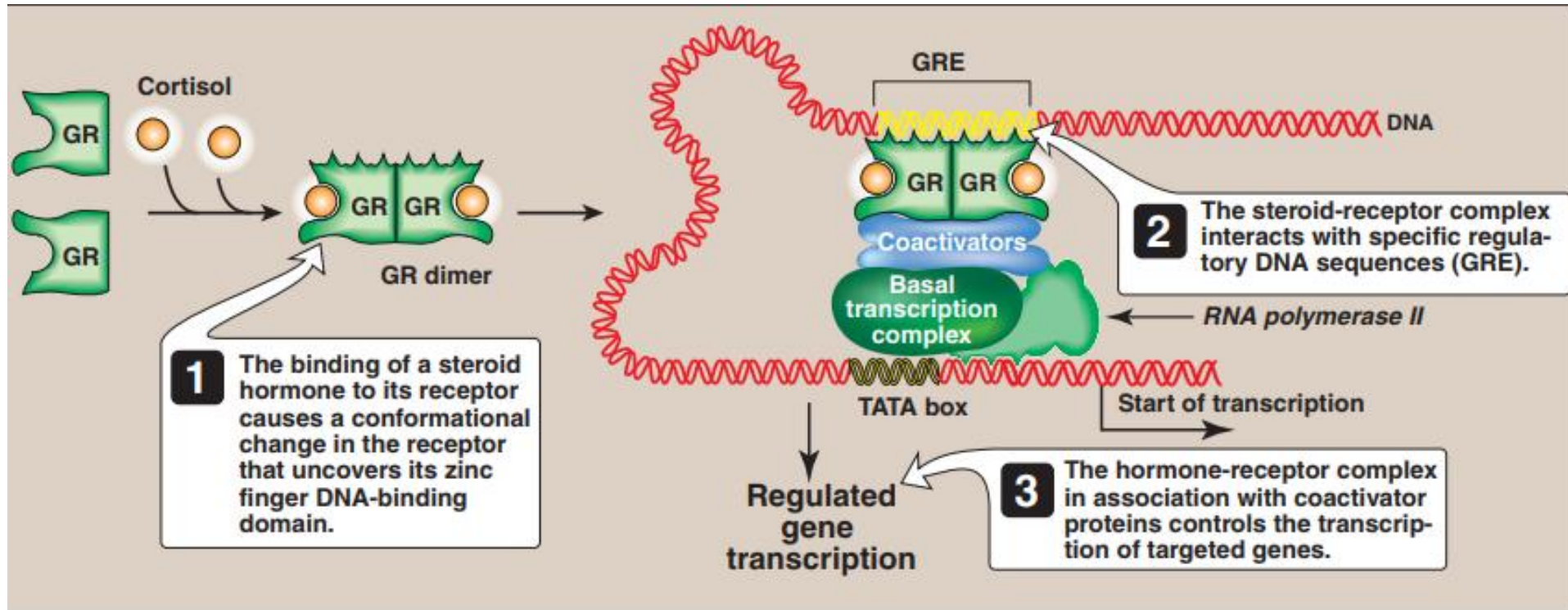

Transcriptional regulation by intracellular steroid hormone receptors.

GRE = glucocorticoid-response element (an example of a hormone response element); GR = glucocorticoid receptor.

Transcriptional regulation by receptors located in the cell membrane.

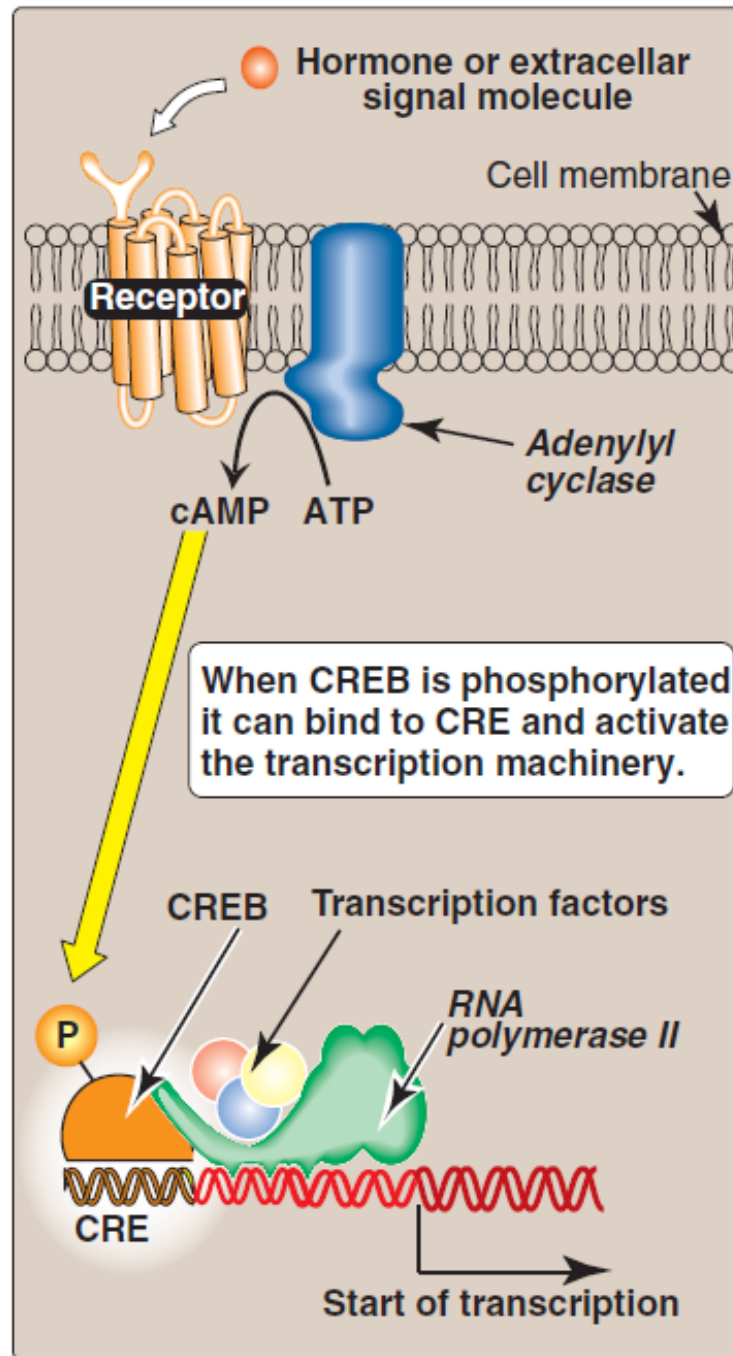

Regulation of Eukaryotic Gene Expression

- **B. Regulation by co- and posttranscriptional processing of mRNA**
 - **1. Splice-site choice/ Alternate splicing**
 - Tissue-specific protein products
 - tropomyosin (TM) regulates the functions of actin in both muscle and nonmuscle cells
 - **2. Alternative polyadenylation**
 - **3. mRNA editing**

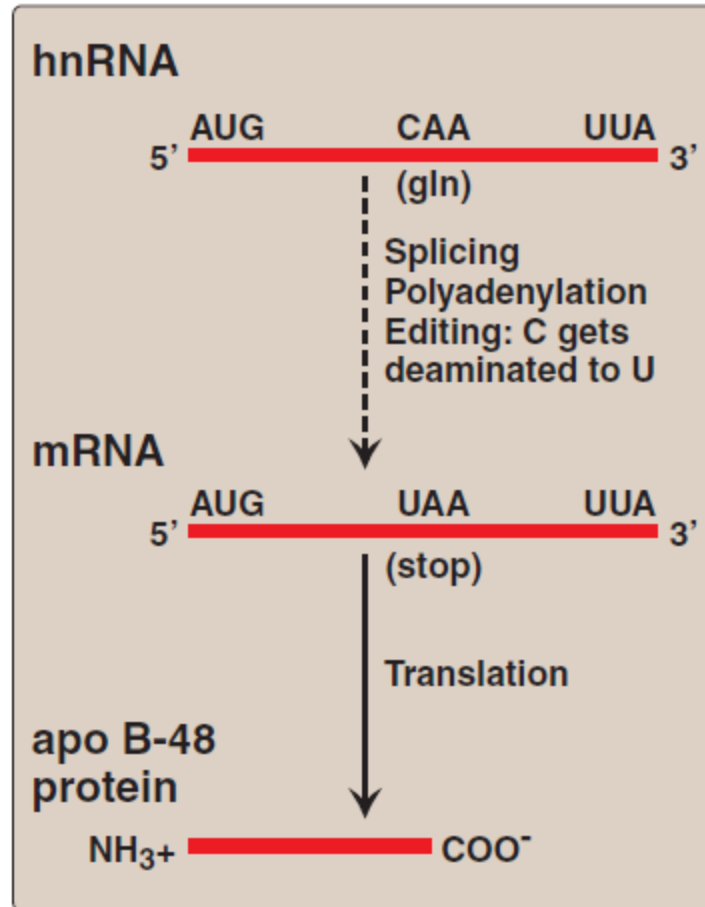

RNA editing of apo B in the intestine and generation of the apo B-48 protein needed for chylomicron synthesis

– 4. mRNA stability

• A. IRON Metabolism

- Regulation by mRNA degradation—Regulation of transferrin receptor (TfR) synthesis

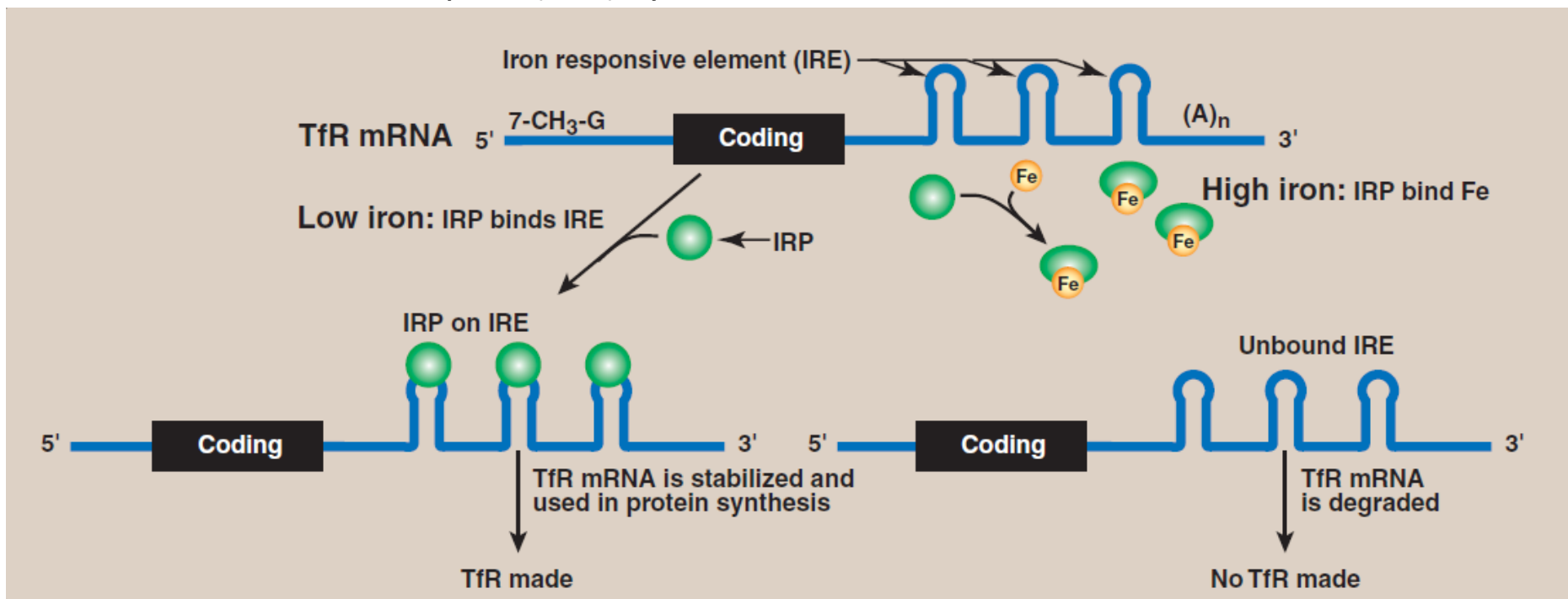

IRE = iron-responsive element; IRP = iron-responsive element binding protein.

- **Ferritin synthesis is regulated at the level of translation**
 - Ferritin mRNA contains IRE at 5' UTR
 - Binding with IRP prevents translation because it overlaps the translation initiation site
 - Iron availability is more: Fe binds to IRP-allows translation of free mRNA of ferritin

- Iron metabolism involves both mRNA stability and translation level

3. mRNA stability

--b. RNA interference (RNAi) by cleavage of target mRNA.

miRNA
si RNA

RNAi therapy:

Age-related macular degeneration (AMD) is triggered by overproduction of vascular endothelial growth factor (VEGF). The siRNA drug targets the mRNA of VEGF and Promotes its degradation- injected in eyes.

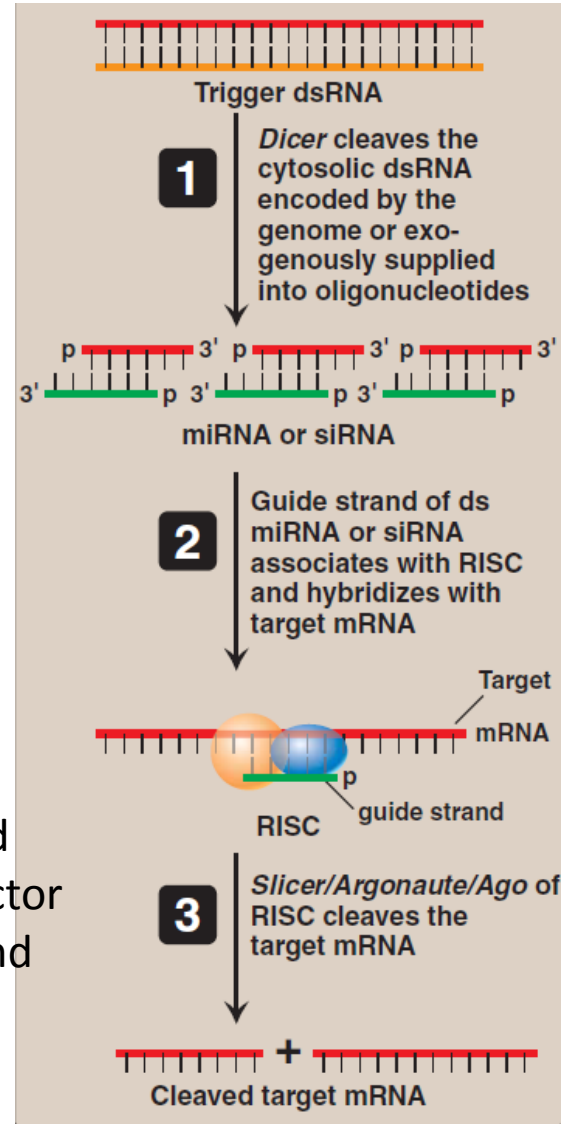

C. Regulation at Translation level

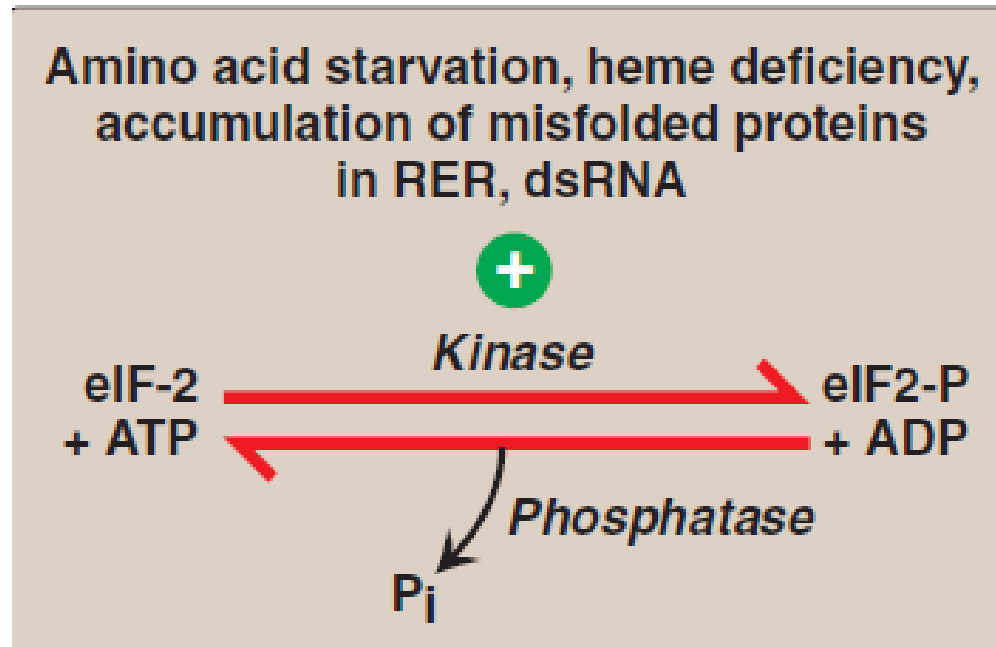

Regulation of translation initiation in eukaryotes by phosphorylation of eIF-2. RER = rough endoplasmic reticulum.

D. Regulation through modifications to DNA

- **1. Access to DNA**
- **2. Amount of DNA:**
- **3. Arrangement of DNA**
- **4. Mobile DNA elements**

1. Access to DNA

- Histone acetylation/deacetylation by the histone acetyltransferase and histone deacetylase enzymes
- Extent of methylation of cytosine bases in CG rich regions (CpG islands) in the promoter region by methyltransferases that use S-adenosyl - methionine as the methyl donor

2. Amount of DNA:

- **Gene amplification** : increase in copy
Number seen in response to particular
chemotherapeutic drugs such as **methotrexate**
 - inhibitor of the enzyme dihydrofolate reductase (DHFR),
 - required for the synthesis of thymidine triphosphate (TTP)
 - in the pyrimidine biosynthetic pathway
- Resistance to the drug

3. Arrangement of DNA

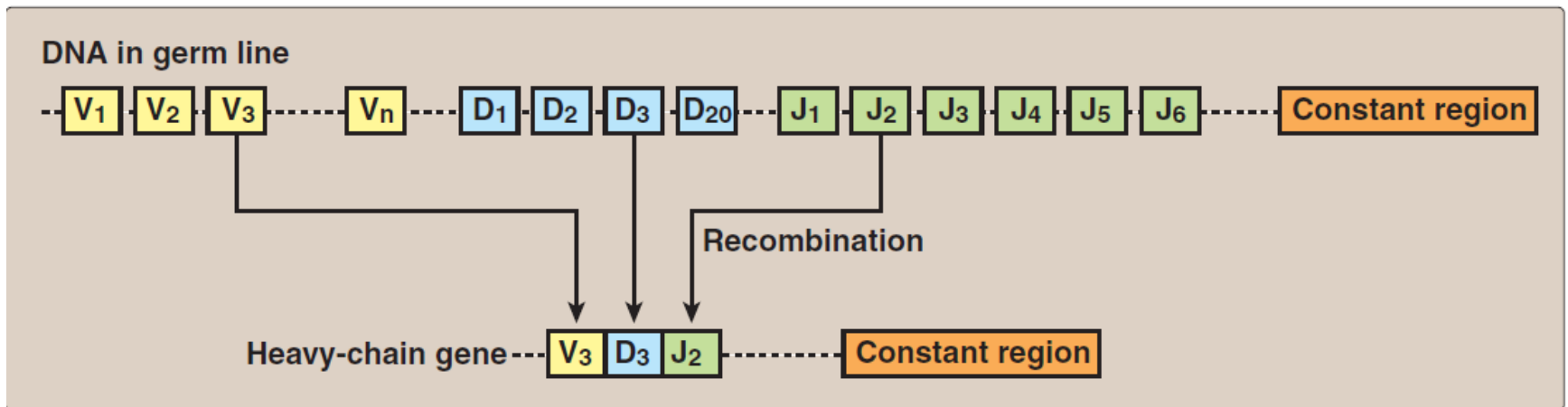

V=Variable, D= Diversity, J= Joining

4. Mobile DNA elements

- Transposons comprise 50% of human genome
- Movement is mediated by transposase
- Movement can be
 - Direct
 - Replicative
 - Retrotransposon (90% of transposon)
 - Hemophilia, Duchenne Muscular dystrophy
 - Antibiotic resistance –Exchange of Plasmids containing Tn carrying antibiotic resistance genes

Summary

- Gene expression results in the production of a functional gene product (either RNA or protein)
- Genes can be either **constitutive** or **regulated**
- Regulation of gene expression occurs **primarily at the level of transcription** in both prokaryotes and eukaryotes
- mediated through the binding of **trans-acting proteins to cis-acting** regulatory elements on the DNA
- In **eukaryotes**, regulation also occurs through **modifications to the DNA**, as well as through **posttranscriptional and posttranslational events**
- In **prokaryotes** **regulation** is achieved through **operons**
- Operon: groups of genes sequentially arranged on the chromosome along with the regulatory elements that determine their transcription
- operon is induced by an isomer of lactose (**allolactose**)
- The **trp operon** is **also regulated by attenuation**

- Transcription of rRNA and tRNA is selectively inhibited in prokaryotes by the **stringent response** to amino acid starvation
- Gene regulation is more complex in eukaryotes. **Operons are not present**, but coordinate regulation of the transcription achieved through the binding of trans-acting proteins to cis-acting elements
- In multicellular organisms coordinated regulation, achieved through binding of **hormone receptor–hormone complex to the DNA**
- **Co and posttranscriptional regulation** is also seen in eukaryotes
- Regulation at the **translational level** can be caused by the **phosphorylation (inhibition) of eIF-2**.
- Gene expression in eukaryotes is also influenced by availability of DNA to the transcriptional apparatus

MCQ1

- Which of the following is the basis for the intestinespecific expression of apoprotein B-48?
- A. DNA rearrangement and loss
- B. DNA transposition
- C. RNA alternative splicing
- D. RNA editing
- E. RNA interference

MCQ 2

- Which of the following is best described as being trans-acting?
- A. CAP site
- B. Operator
- C. Promoter
- D. Repressor

MCQ 3

- Which of the following is most likely to be true in hemochromatosis, a disease of iron accumulation in the body?
- A. The mRNA for the transferrin receptor (TfR) is stabilized by the binding of IRPs to 3' stem-loop structures known as IREs.
- B. The mRNA for the TfR is not bound by IRPs, and is rapidly degraded.
- C. The mRNA for apoferritin is not bound by IRPs at its 5' stem-loop IRE, and is translated.
- D. The mRNA for apoferritin is bound by IRPs, and is not translated.
- E. Both B and C

MCQ 4

- After several weeks of chemotherapy with methotrexate, a cancer patient's tumor begins to show signs of resistance to treatment. Which of the following mechanisms is most likely to explain this resistance to methotrexate?
- A. Deficiency of thymidylate synthase
- B. Overproduction of xanthine oxidase.
- C. Deficiency of PRPP synthase.
- D. Deficiency of thymidine kinase.
- E. Overproduction of dihydrofolate reductase

DNA regulatory protein

- Proteins that regulate gene expression:
Repressor, enhancer, silencer
- These proteins show several motifs which are involved in these DNA protein interaction
- Only a small part of the protein has direct contact with DNA
- Interactions are reversible and involve non covalent bonds
- Some commonly seen structural motifs

- Helix turn helix motif
- Zinc finger motif
- Leucine Zipper motif

Helix turn helix motif

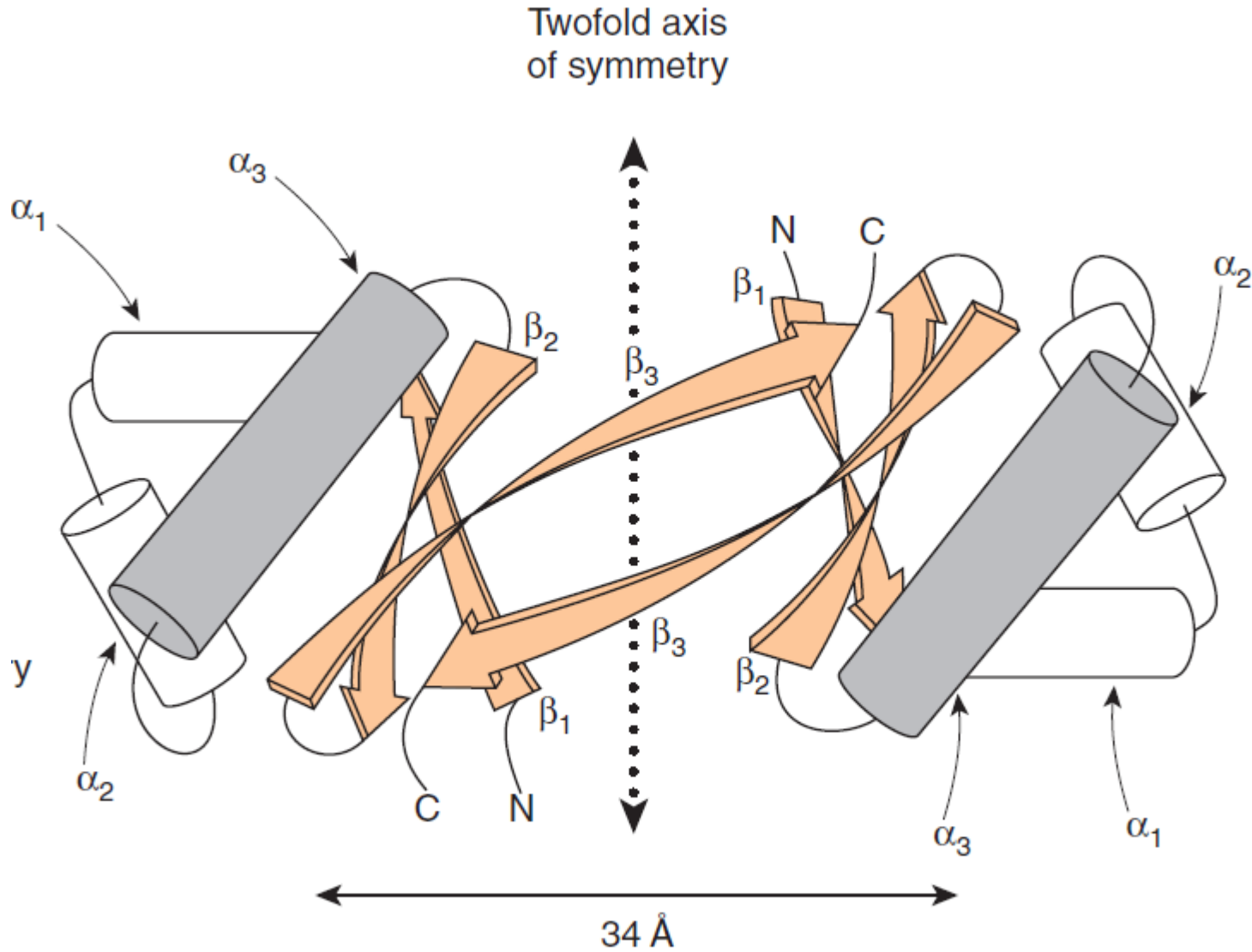

E.g. Lambda repressor, CAP protein, Tryptophan repressor, Homeobox protein in mammals

Zinc fingers are a series of repeated domains (two to nine) in which each is centered on a tetrahedral coordination with zinc.

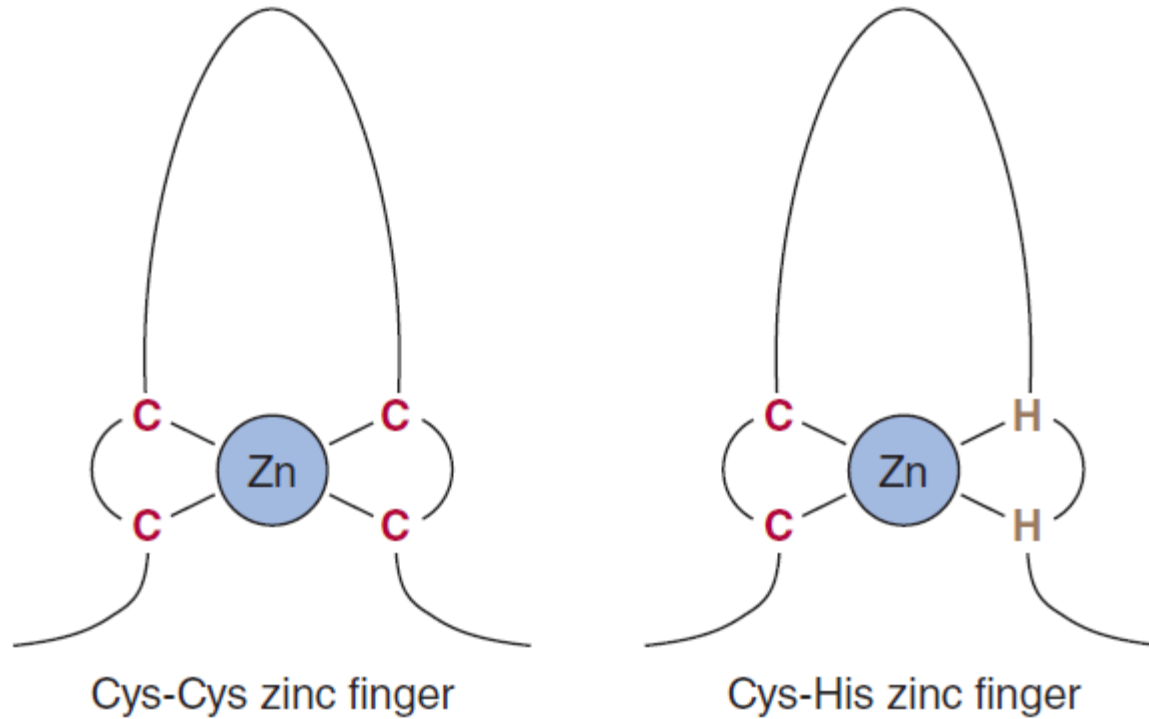

Steroid thyroid receptor protein and calcitriol (vitamin D) receptor protein

The leucine zipper motif

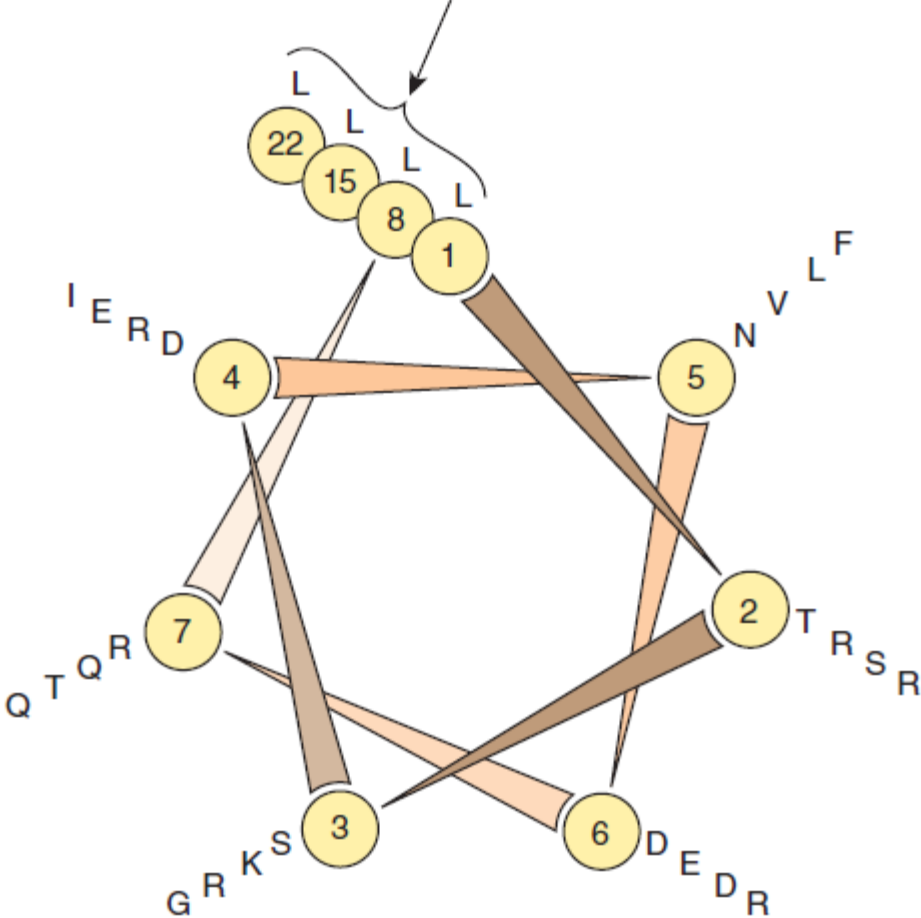

A schematic model of the DNA-binding domain of C/EBP

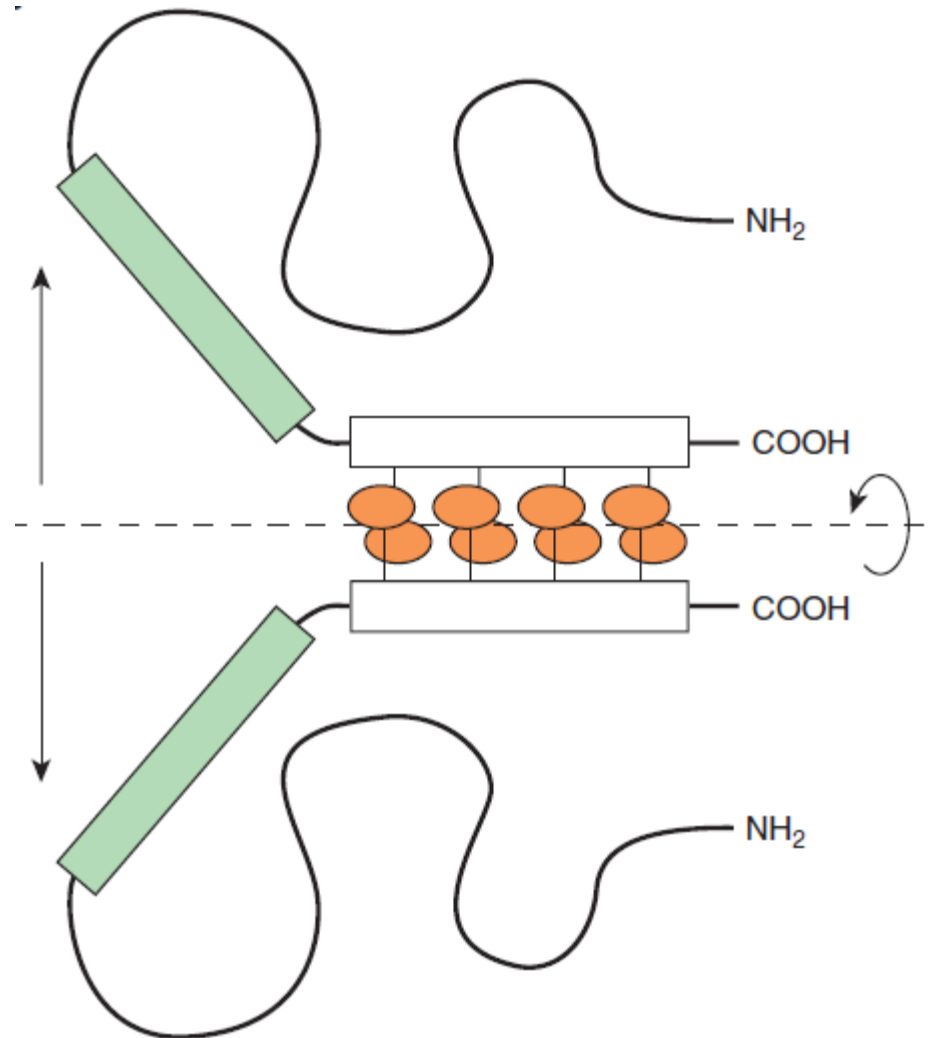

Transcription Factors That Contain DNA Binding Motifs

Binding Motif	Organism	Regulatory Protein
Helix-turn-helix	<i>E coli</i>	lac repressor, CAP
	Phage	λ cl, cro, and 434 repressors
	Mammals	Homeobox proteins Pit-1, Oct1, Oct2
Zinc finger	<i>E coli</i>	Gene 32 protein
	Yeast	Gal4
	<i>Drosophila</i>	Serendipity, hunchback
	Xenopus	TFIIIA
	Mammals	Steroid receptor family, Sp1
Leucine zipper	Yeast	GCN4
	Mammals	C/EBP, fos, Jun, Fra-1, CRE binding protein (CREB), c-myc, n-myc, l-myc

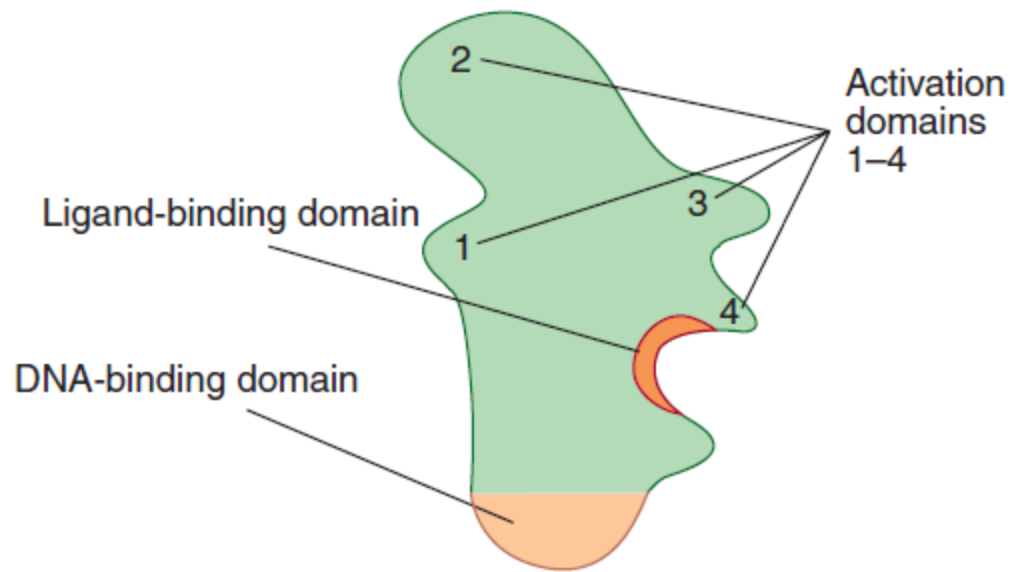

References

- Harper's Illustrated Biochemistry-30th edition
- Lippincott's Illustrated Reviews: 5th edition
- Lehninger Principles of Biochemistry
- Biochemistry 4th edition Donald Voet and Judith G. Voet.